

TEENAGE MUTANT NINJA TURTLES

BATTLE BIKE RAPH INSTRUCTIONS

1. Get ready to cruise into battle and kick some shell! First, snap both Fork-mounted Missile units on to both the left and right sides of the Combat Cruiser's front fork. You are now ready to press their buttons and fire!

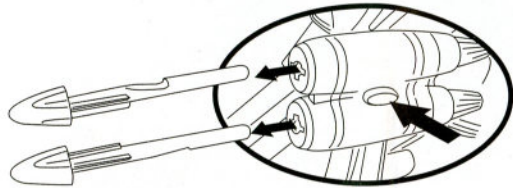

2. Next, choose your weapons for battle! With your parent's help, carefully cut the weapons from the Ninja Warrior Weapons Wall. (You can later use the holding pieces in the Weapons Wall to store your weapons when not in use.)

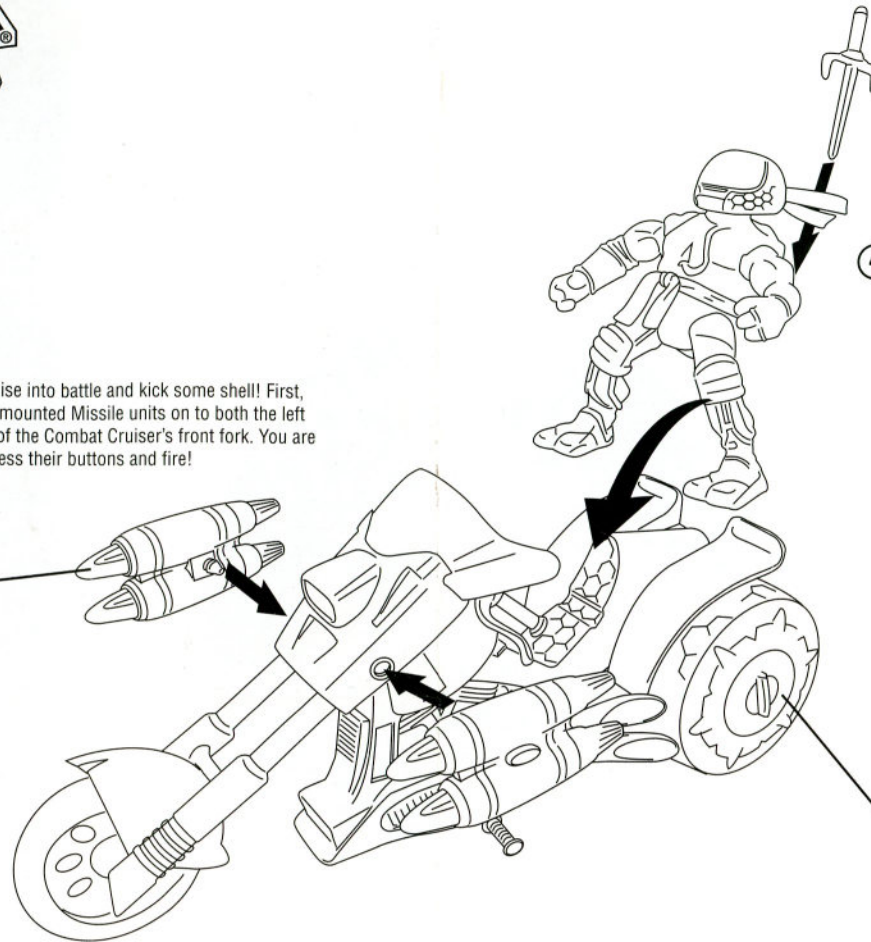
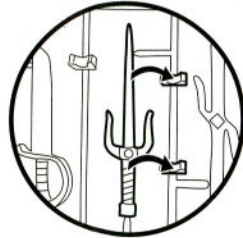
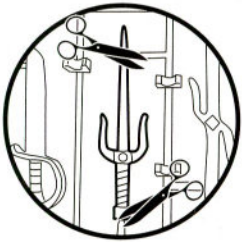

4. Finally, attach Raph's Trusty Twin Sais to his back, seat Raph on his Battle Cruiser and place his hands on the adjustable handle bars and his feet on the adjustable foot pegs! Time to cruise!

3. Now snap on both back tires' Battle Armor Wheel Shields.

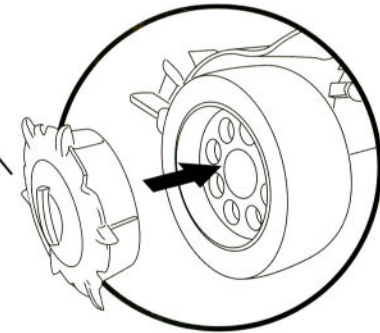

Teenage Mutant Ninja Turtles® © 2005 Mirage Studios, Inc. Teenage Mutant Ninja Turtles®, Leonardo®, Michelangelo®, Raphael®, Donatello®, Splinter®, Shredder®, and Foot Soldier® are registered trademarks of Mirage Studios, Inc. All Rights Reserved. PRINTED IN CHINA.

Age 4 and up

Playmates ASST. NO. 53170
STOCK NO. 53180

Before giving to a child, please keep the runner frame after removal of weapons.
When removing weapons, parents should trim off any excess plastic using scissors or other suitable tool.
Do not use projectile other than those provided by the toy.

WARNING: CHOKING HAZARD
Small parts. Not for Children under 3 years.